



# Teaching Gratitude My Gratitude Cape

## You will need

- photocopies from the appendix, one for each student
- decorative stuff (stickers, colour markers, glitter etc)
- ribbons

1. Use either coloured photocopies or the BW ones for all the students. Consider to print it in A3 if possible.
2. Tell students to write down anything they are grateful for on the cape and decorate it.
3. After completing each cape the children should cut it out and adjust a ribbon on it. You will need a 50-60 cm piece of ribbon for each cape.



Teaching Gratitude  
**My Gratitude Cape**

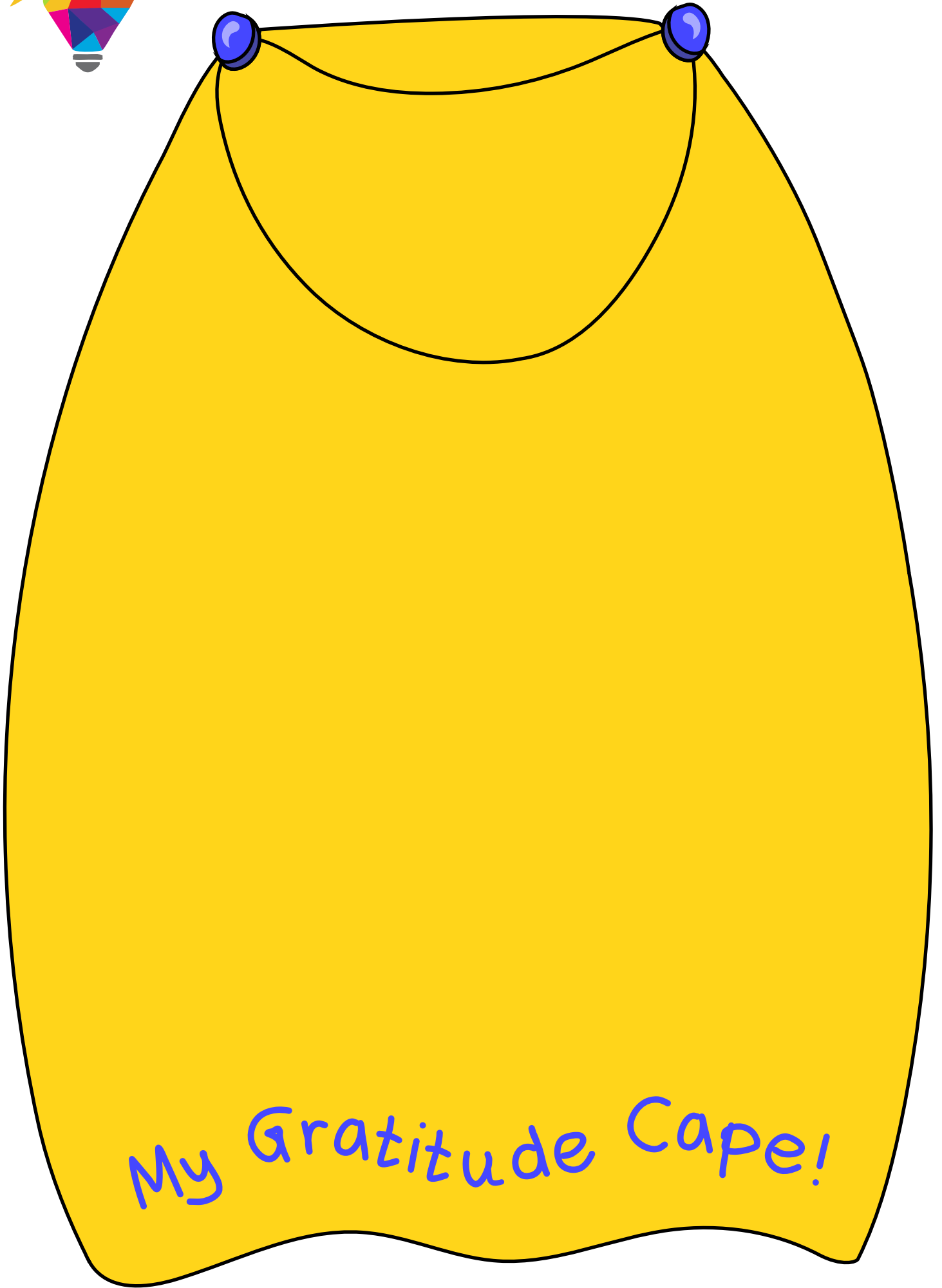

My Gratitude Cape!





Teaching Gratitude  
**My Gratitude Cape**

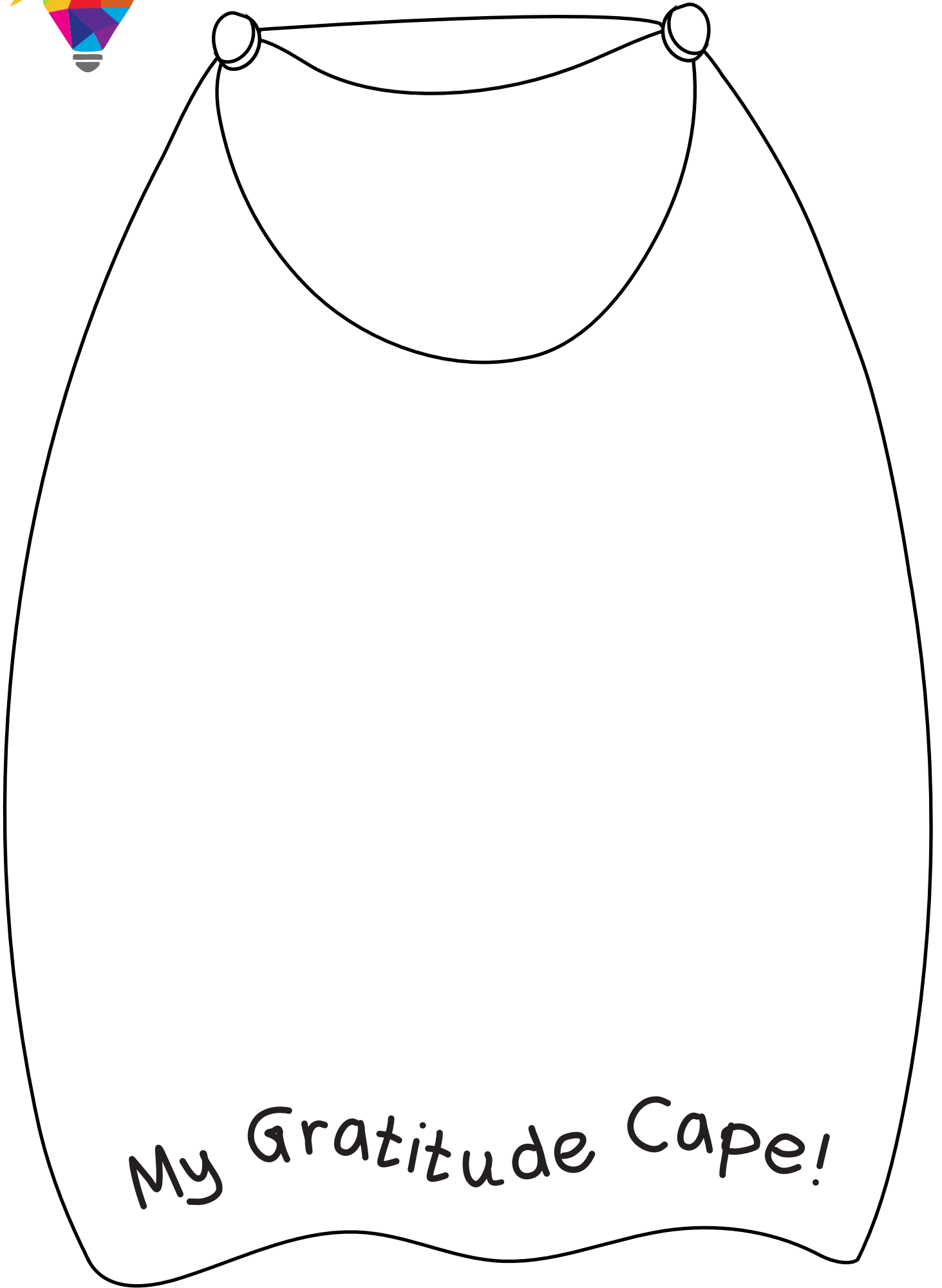

My Gratitude Cape!



# Teaching Kindness My Love Glasses

## You will need

- photocopies from the appendix, one for each student
- A4 pieces of cardboard
- glue

1. Use either coloured photocopies or the BW ones for all the students. Print in A4.
2. Glue the photocopy on a piece of cardboard.
3. Cut out the glasses and use them during the task.

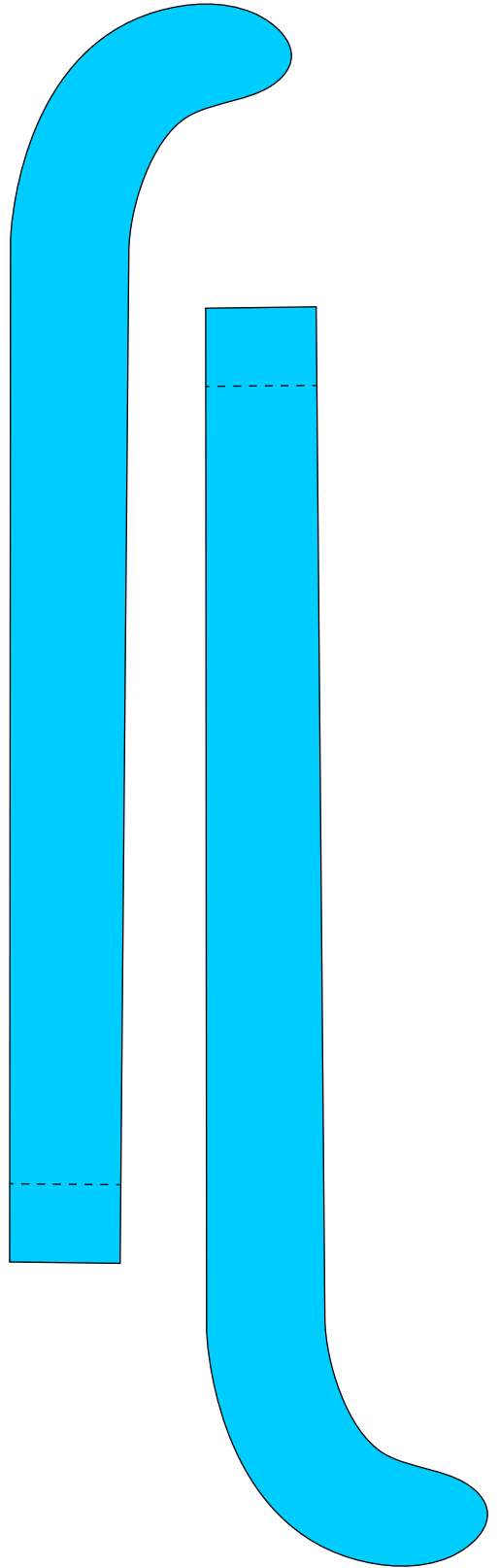
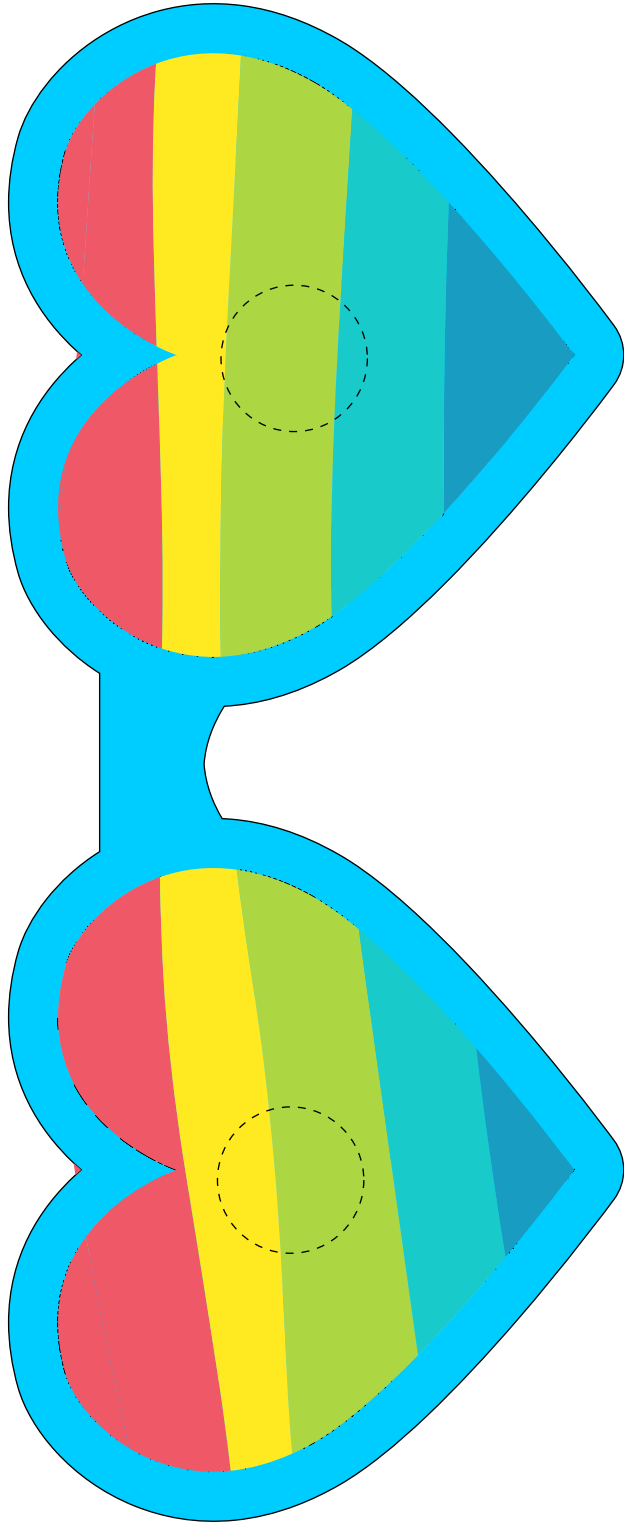

Teaching Kindness  
**My Love Glasses**

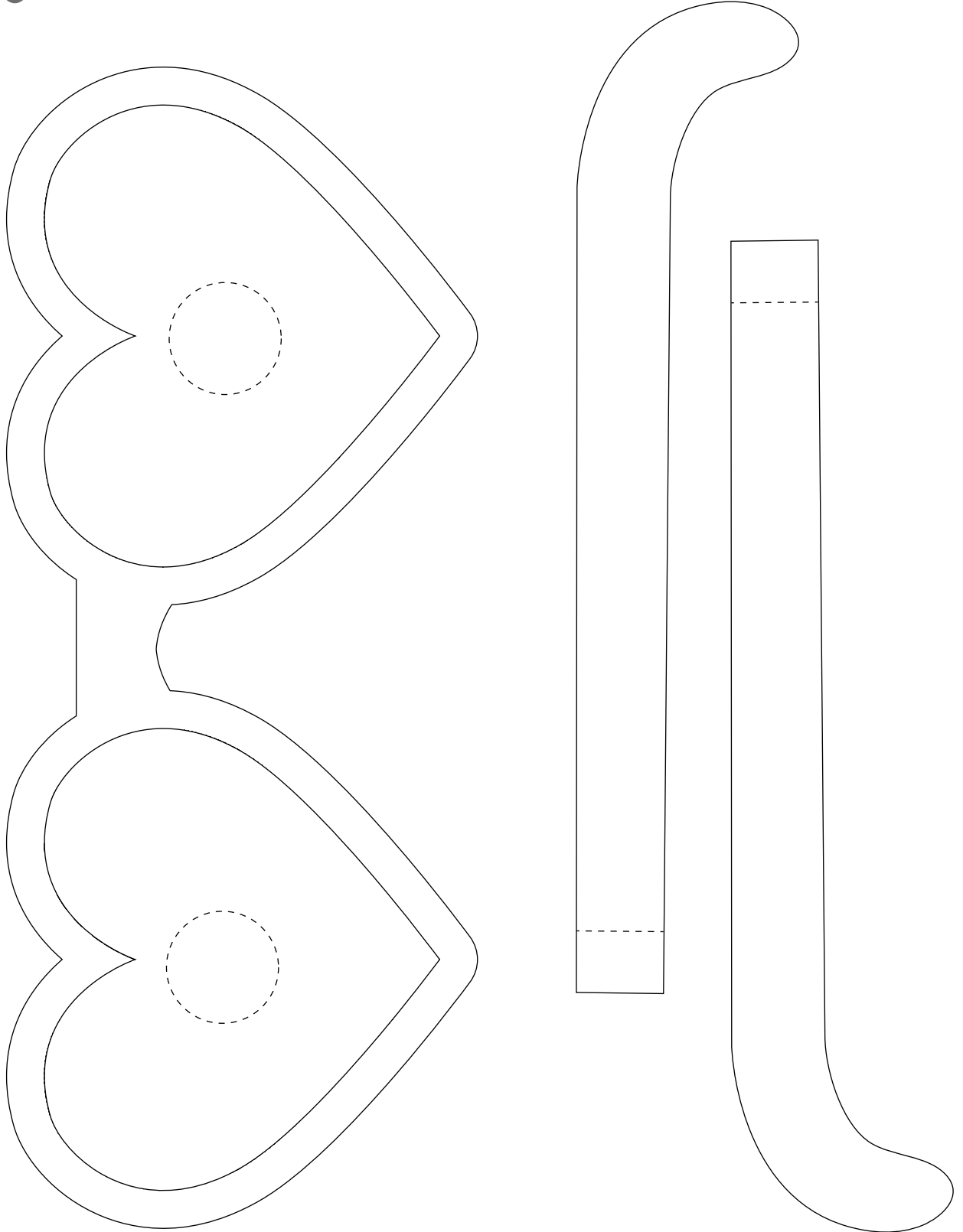

Teaching Kindness  
**My Love Glasses**



## Teaching Kindness My Love Dice

1. *Print in A4.*
2. *Glue the photocopy on a piece of cardboard.*
3. *Cut out the dice, assembly it and use it during the task.*

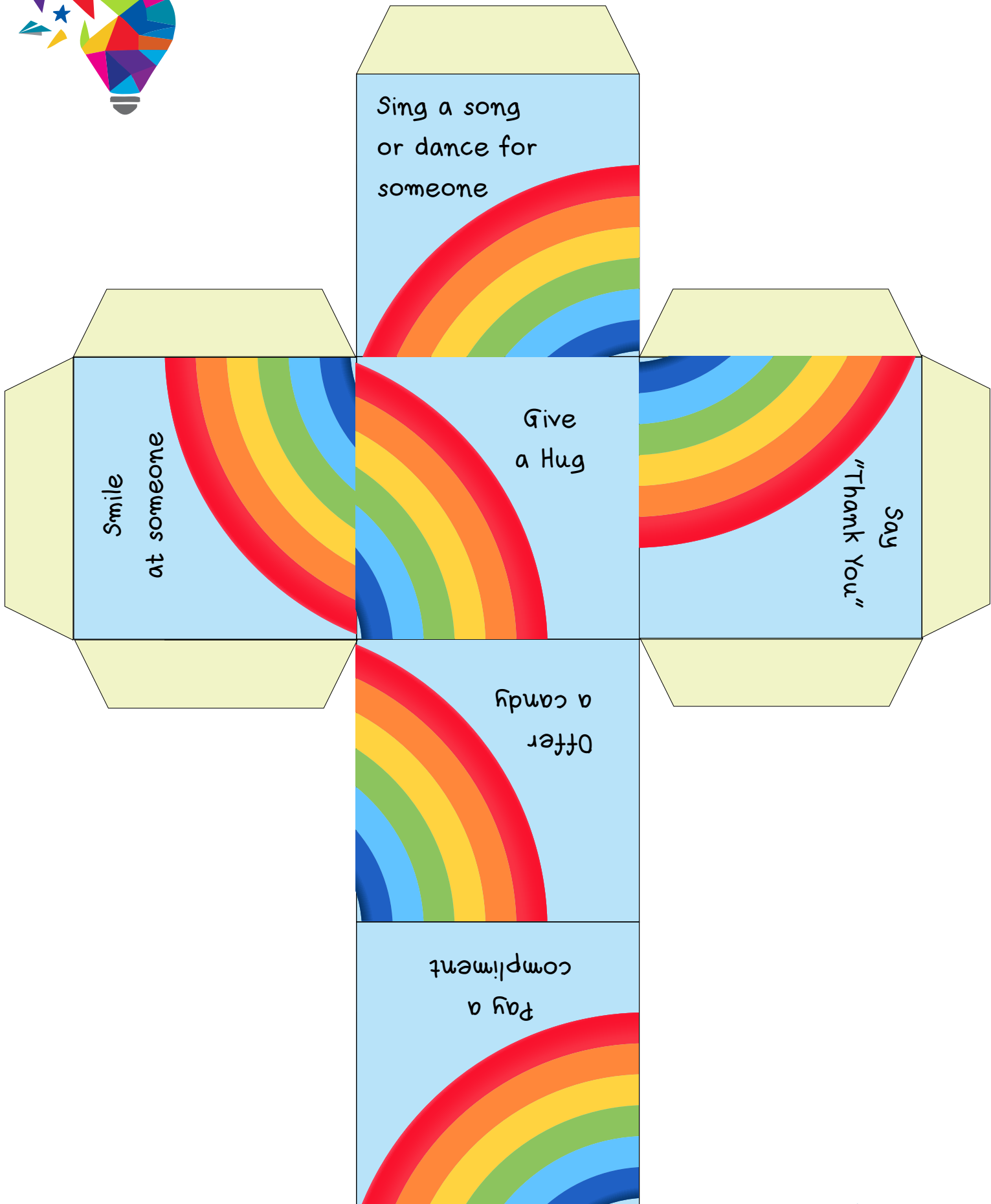



# Teaching Resilience My Magic “Help Myself” Toolbox

## You will need

- a box or an envelope
- photocopies of the label and the tools (for each student)
- glue

1. Use a box or an envelope and stick the toolbox label on it. This will be your Magic “Help Myself” Toolbox.
2. Tell students to cut down all the tools, or prepare them yourself before hand in order to save time
3. Together with your students decide which phrase should be written on each tool.
4. Place the tools in the toolbox.



Teaching Resilience  
**My Magic "Help Myself" Toolbox**



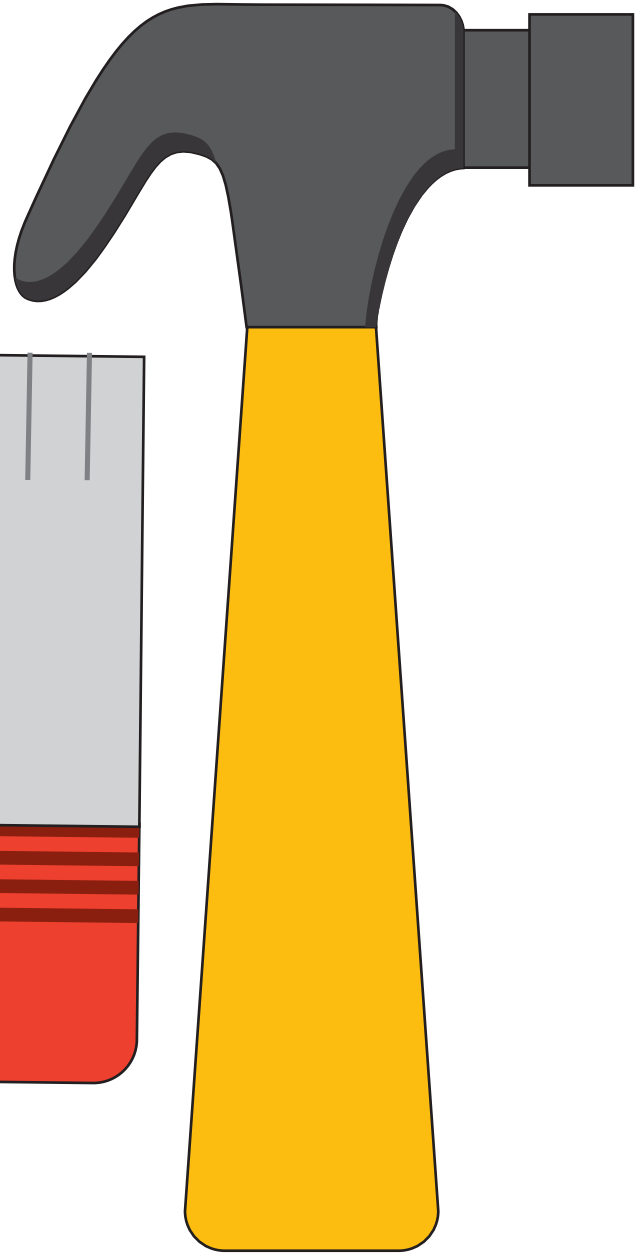
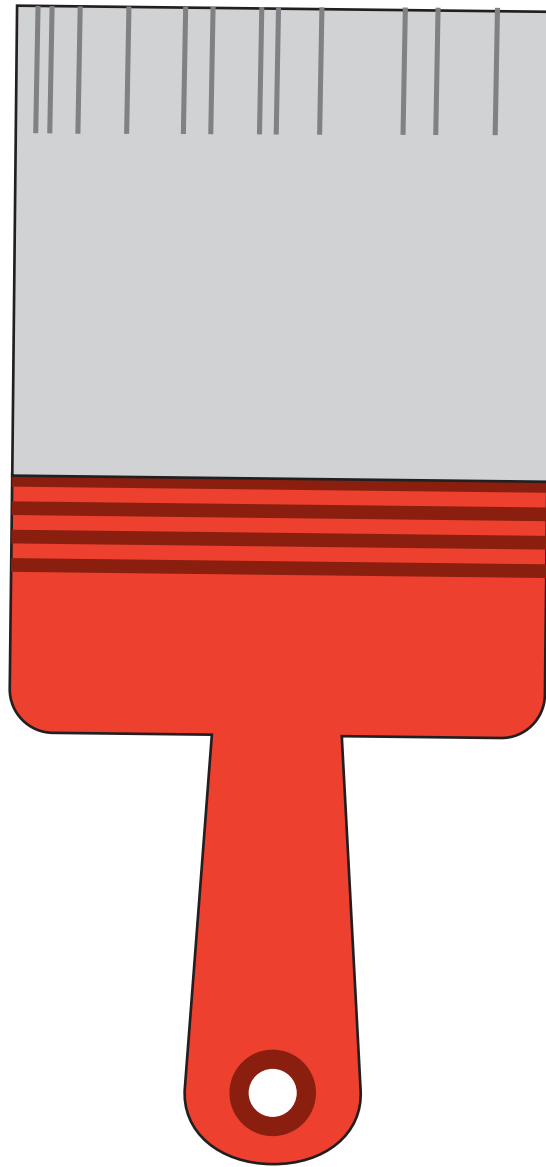
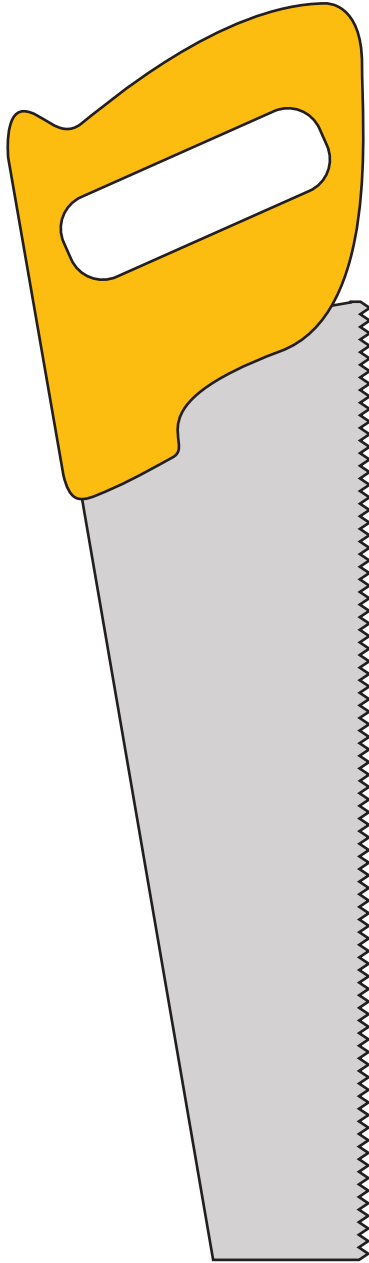

Teaching Resilience  
**My Magic “Help Myself” Toolbox**

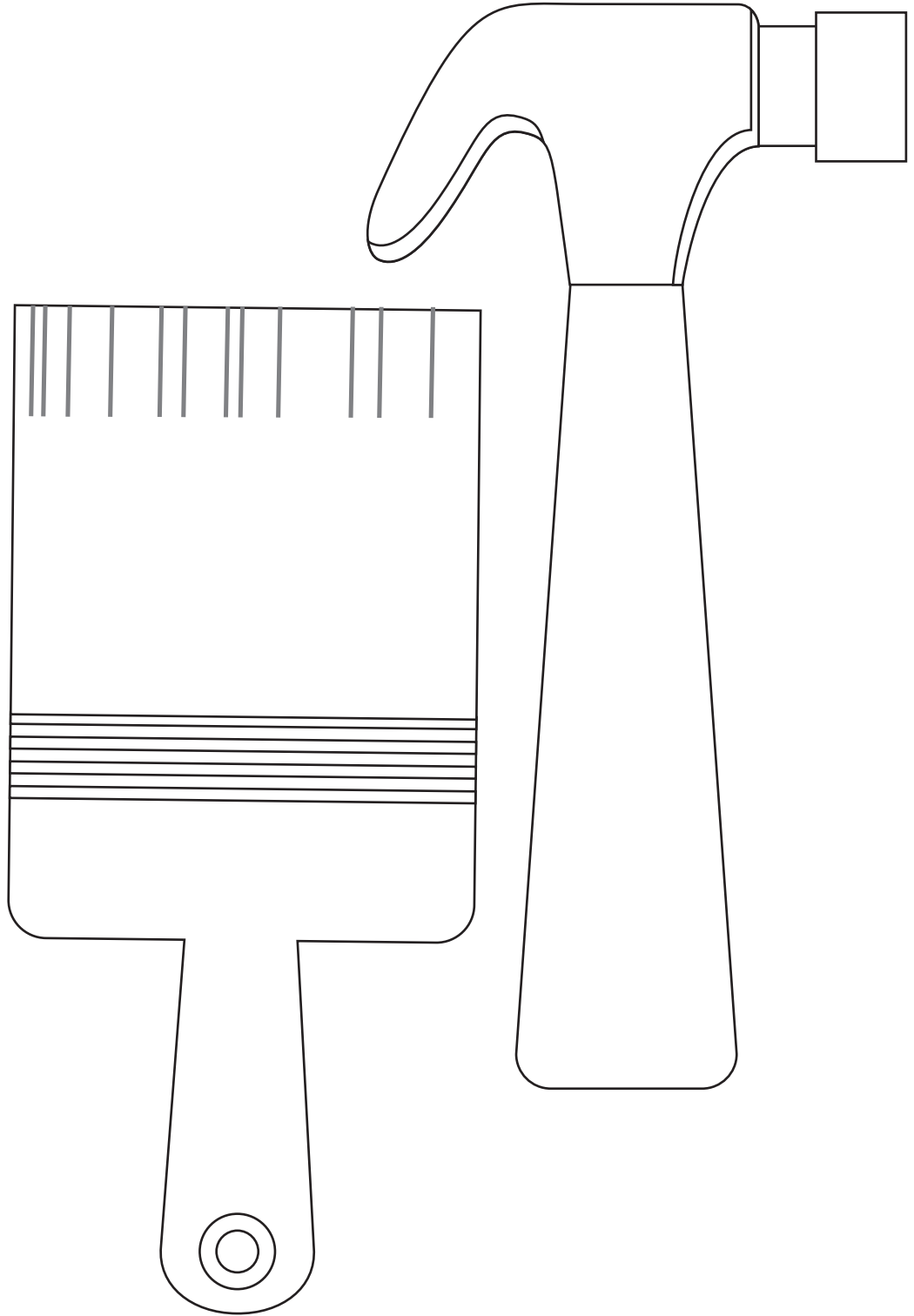
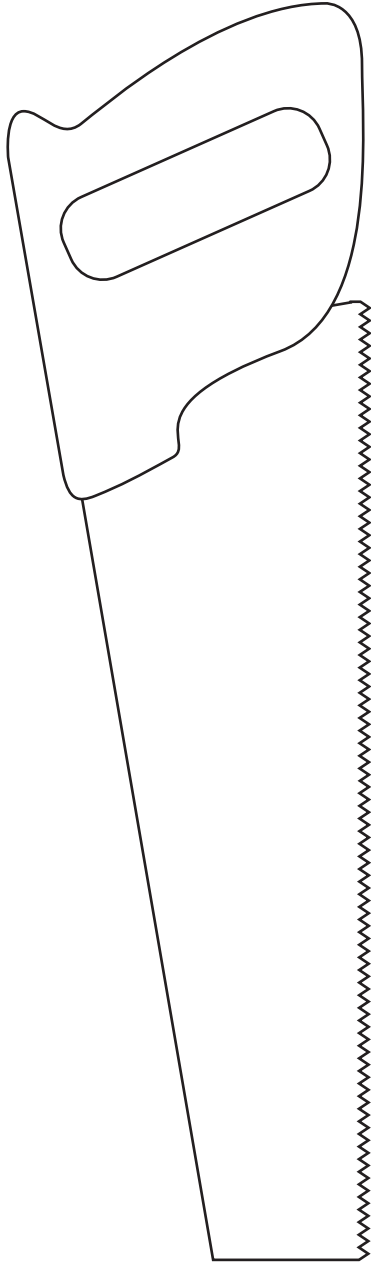

Teaching Resilience  
**My Magic "Help Myself" Toolbox**

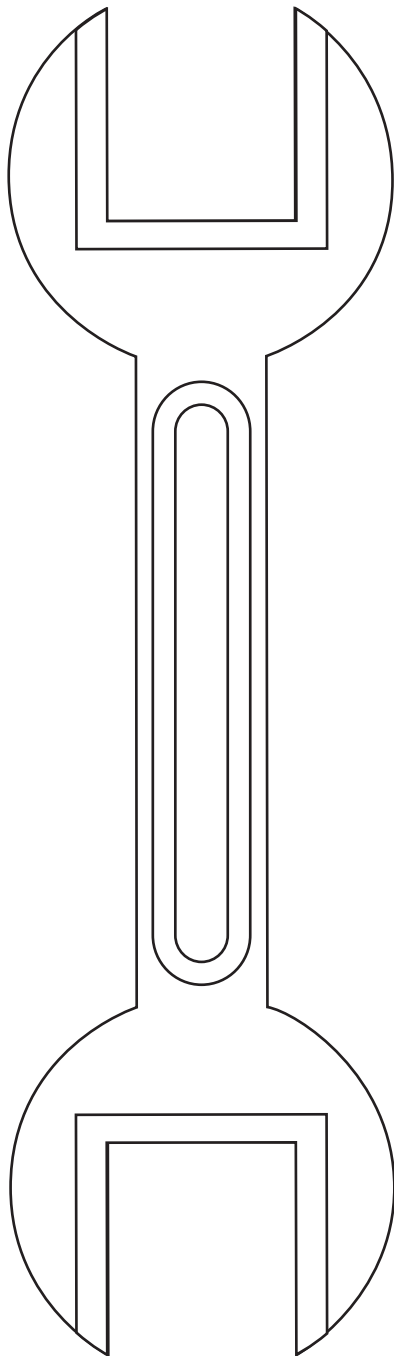
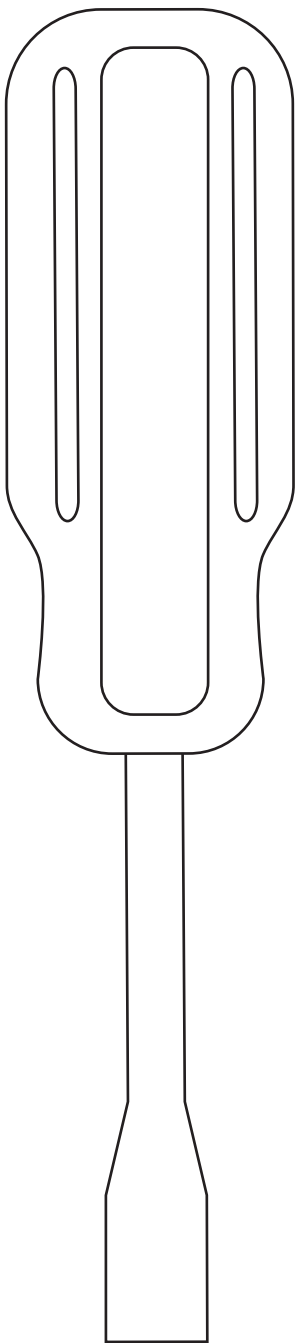
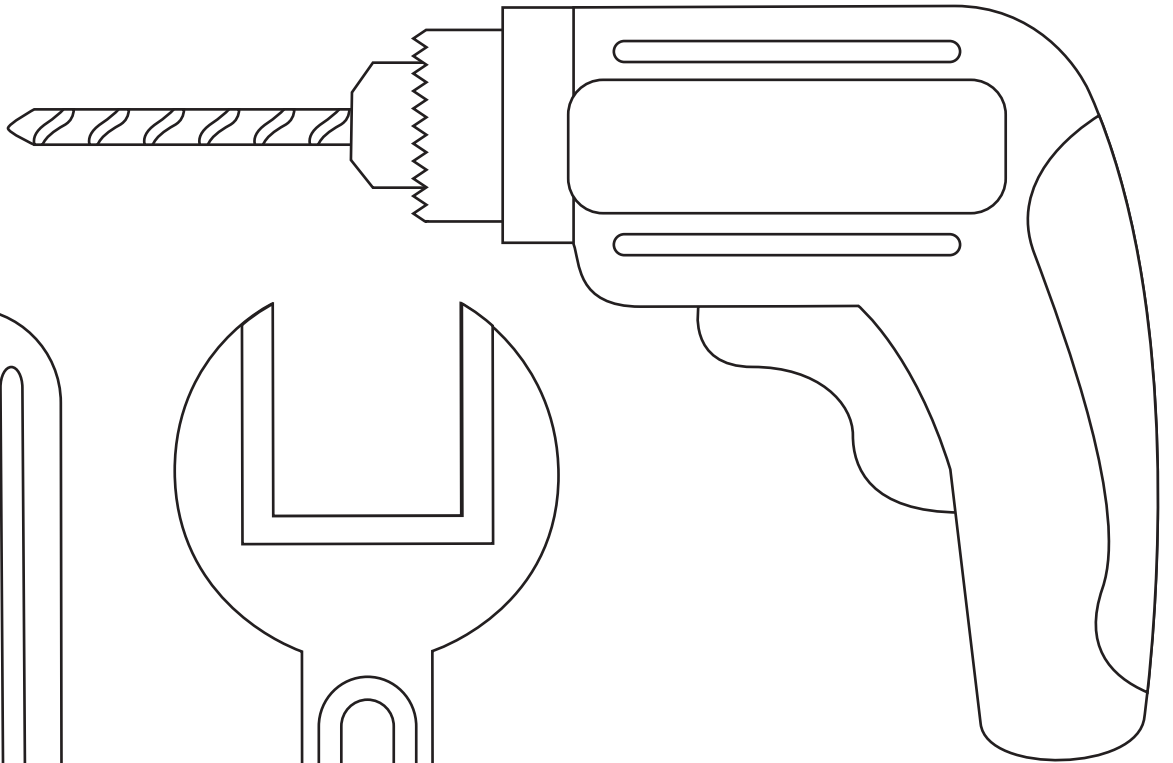

Teaching Resilience  
**My Magic "Help Myself" Toolbox**

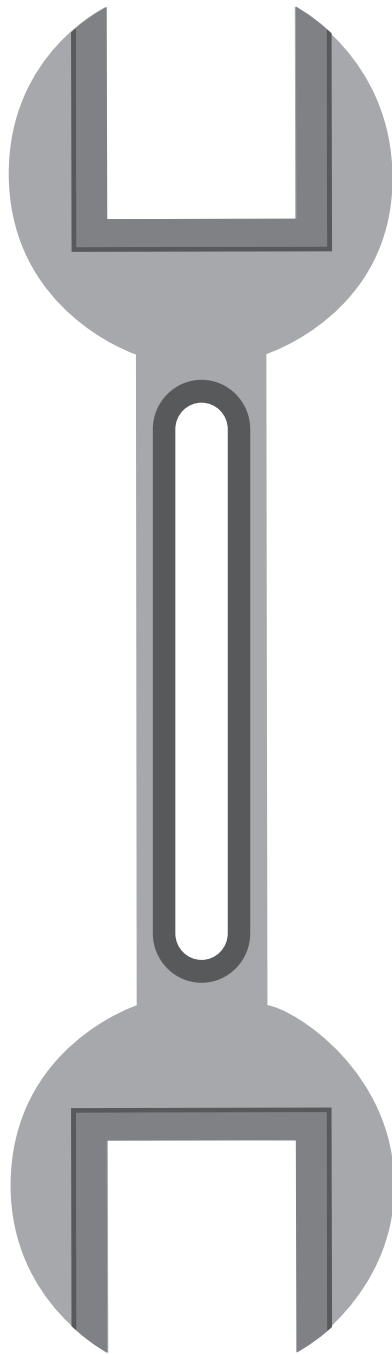
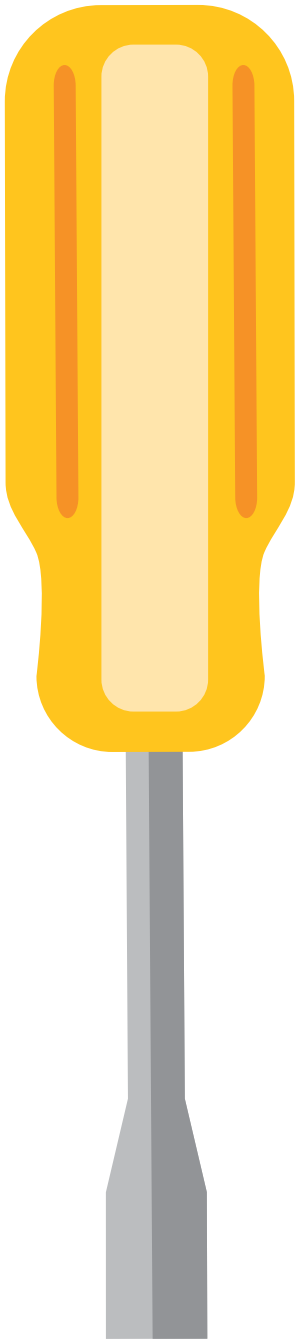

Teaching Resilience  
**My Magic "Help Myself" Toolbox**



# Teaching Character Strength

## My Strength Badge

### You will need

- photocopies from the appendix, one for each student
- glue
- safety pins or pieces of velcro to adjust the badge on the clothes

1. Use either coloured photocopies or the BW ones for all the students.
2. Tell students to write down their positive adjectives on the ribbons. Be sure to leave space on the upper side of the ribbon for the glue.
3. The children should cut it out and adjust the ribbons to the badge.



# Teaching Character Strength

## My Strength Badge

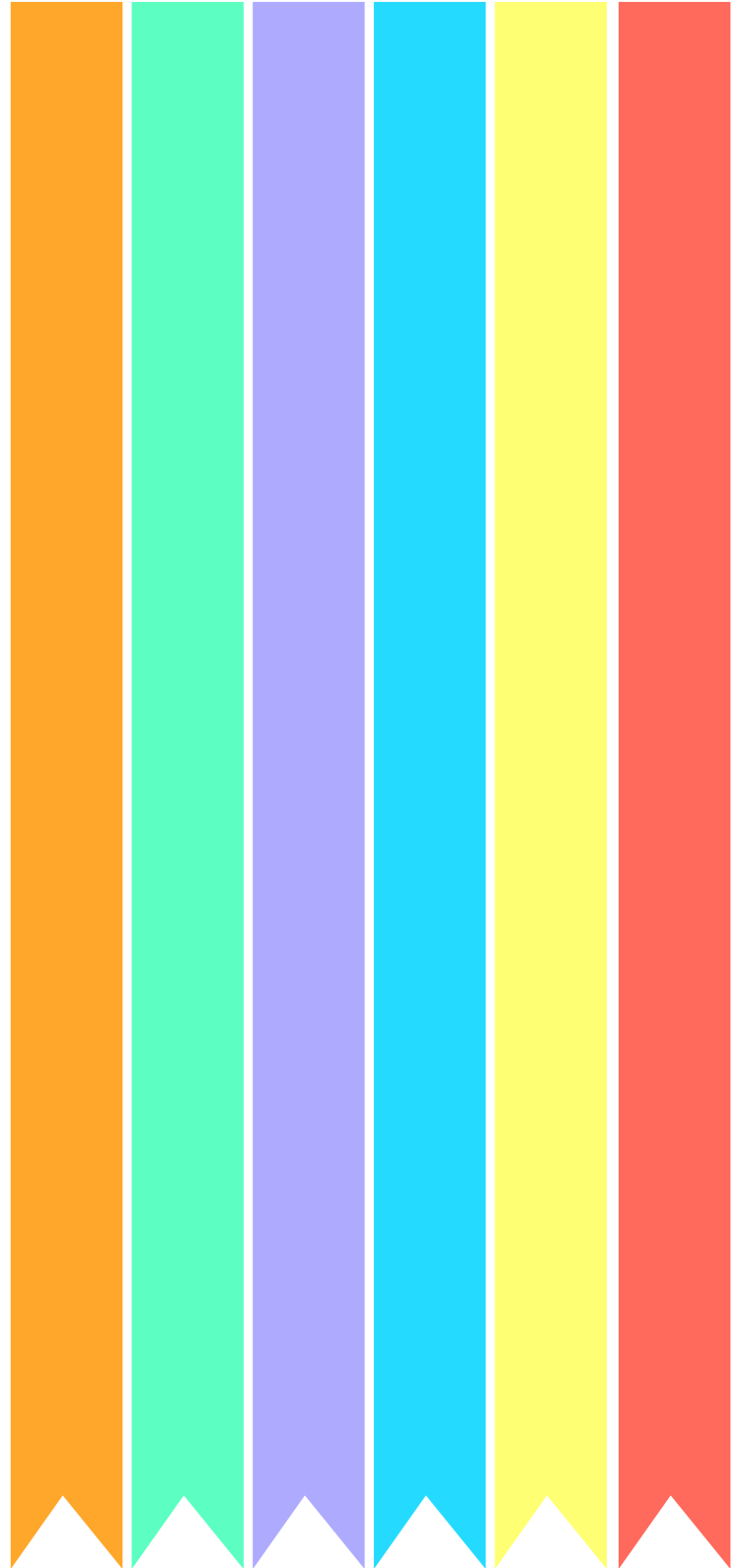



# Teaching Character Strength

## My Strength Badge



--	--	--	--	--	--



# Teaching Collaboration My Friendship Pizza

## You will need

- 2 photocopies from the appendix, to assembly the pizza doe. Print in A3 if possible.
- a piece of cardboard (35x50cm)
- a few pages of the pizza ingredients (A4) according to the number of students in the class
- glue

1. Assembly the pizza doe by gluing the 2 halves side by side on the cardboard
2. Tell students to cut down all the ingredients, or prepare them yourself before hand in order to save time
3. Together with your students decide which friendship ingredient should be written on each pizza ingredient.
4. Stick the ingredients to the doe and finish the pizza.



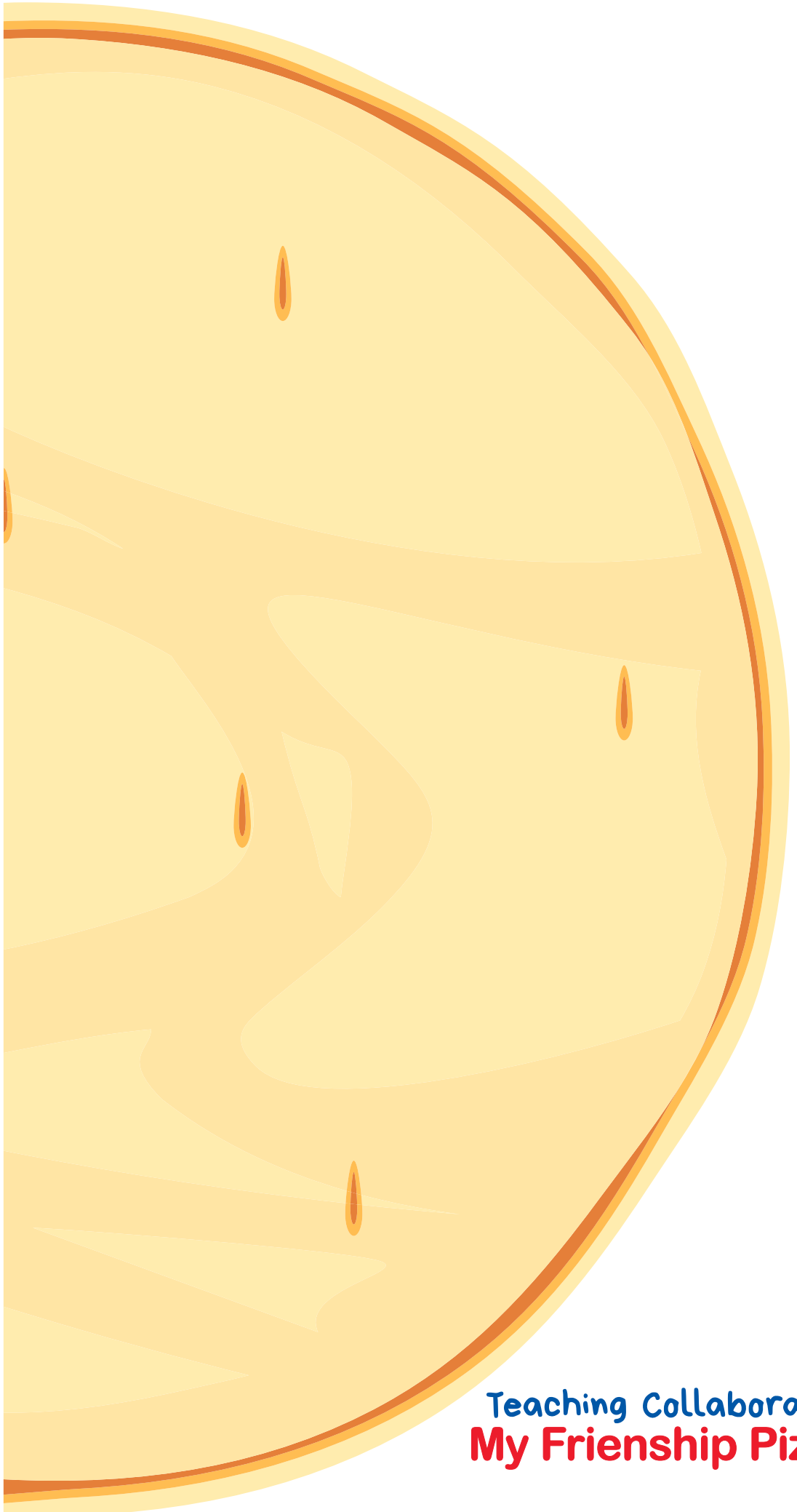

Teaching Collaboration  
**My Friendship Pizza**

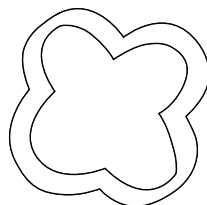
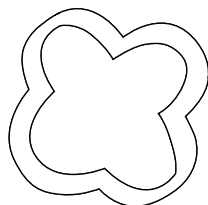
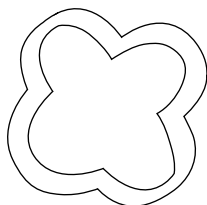
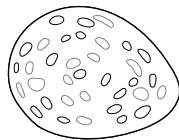
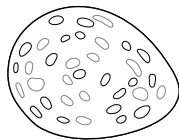
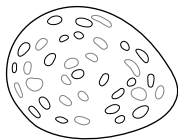
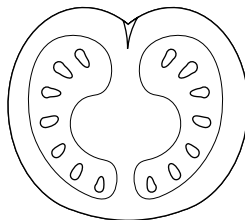
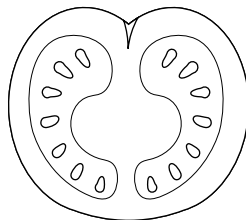
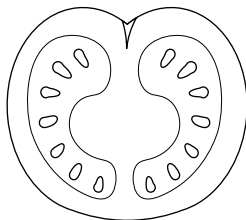
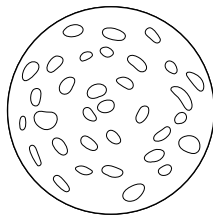
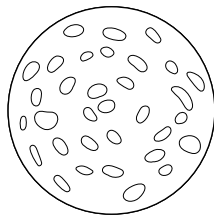
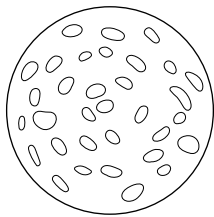
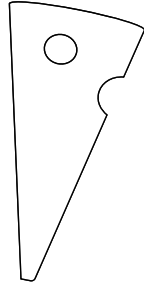
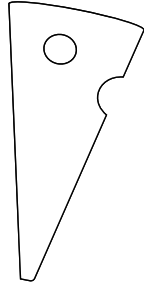
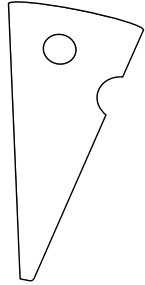

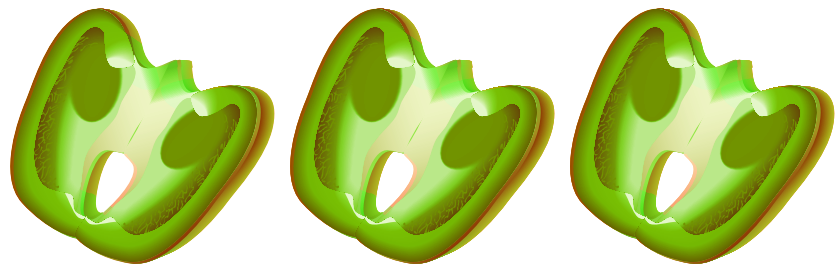
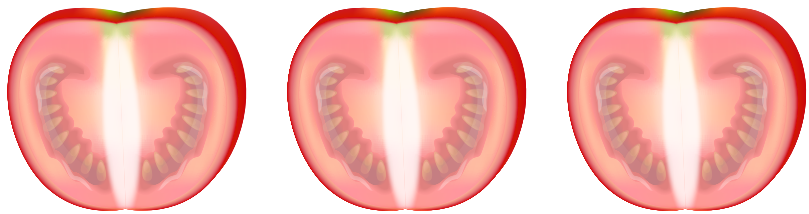
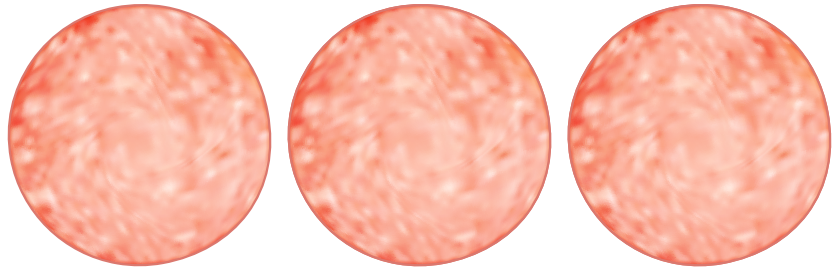

Teaching Collaboration  
**My Friendship Pizza -Toppings**



# Teaching Mind Growth My Life Gaming Controller

## You will need

- photocopies of the controllers and the buttons from the appendix, one set for each student
- A4 pieces of cardboard
- glue or velcro to adjust the buttons to the controller

1. Use either coloured photocopies or the BW ones for all the students. Print in A4.
2. Glue the photocopy on a piece of cardboard.
3. Cut out the controller
4. Write the things you can control on the buttons and adjust them to the controller with glue or velcro



# Teaching Mind Growth My Life Gaming Controller

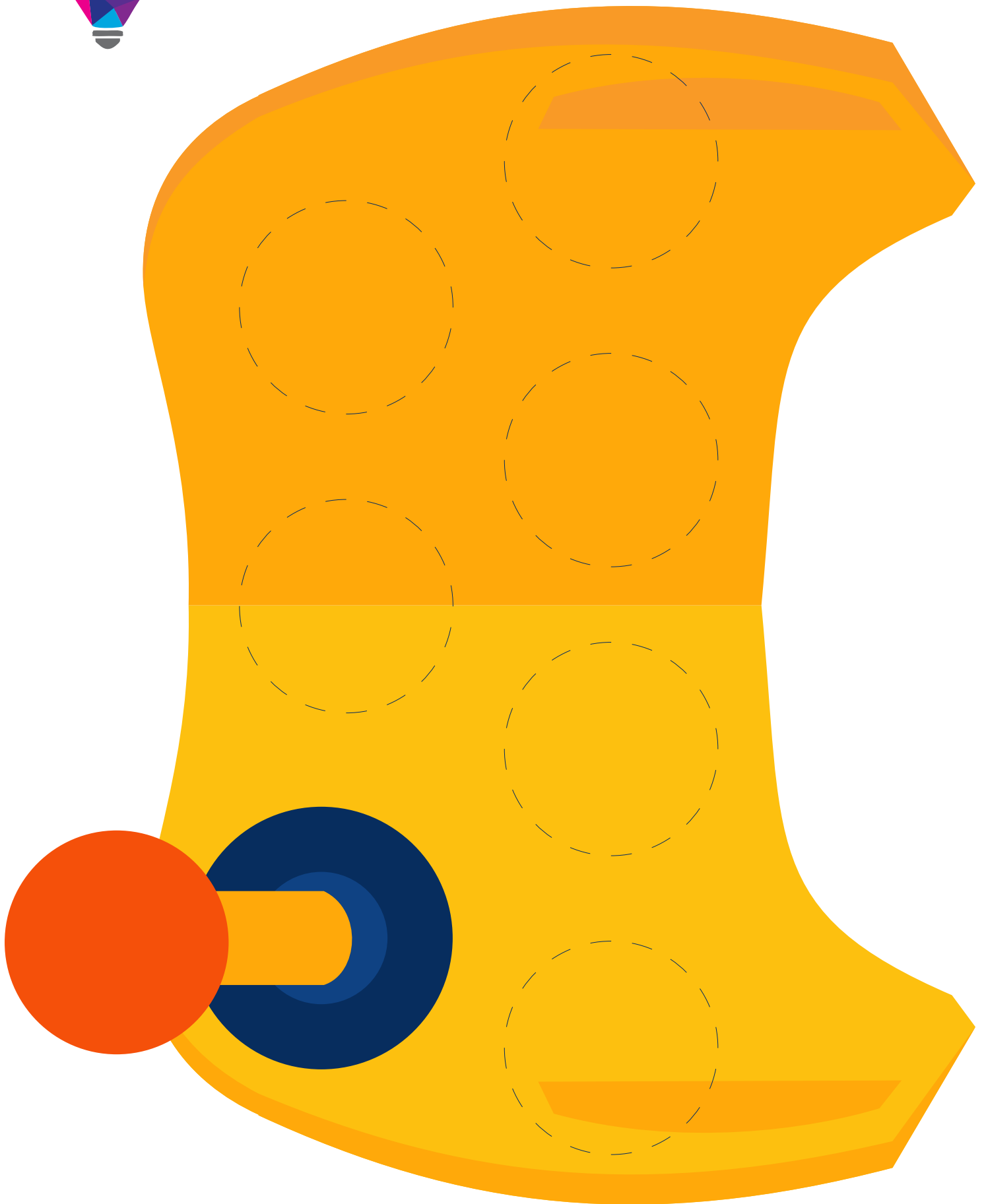



# Teaching Mind Growth My Life Gaming Controller

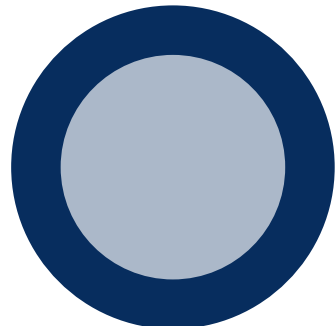
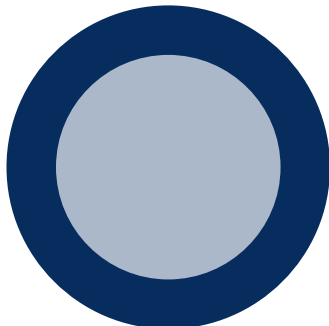
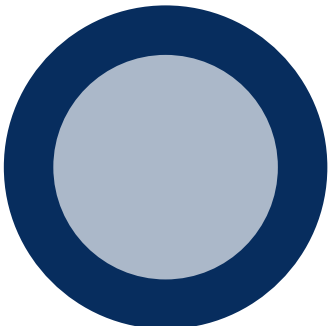
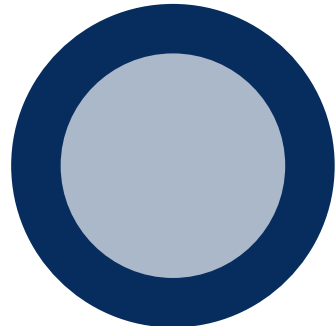
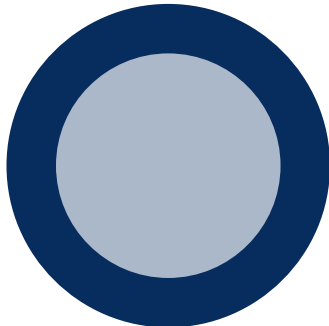
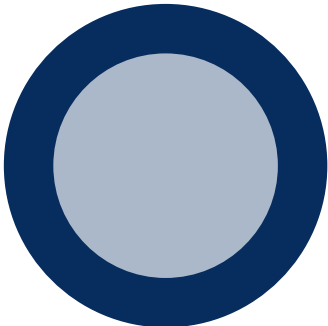
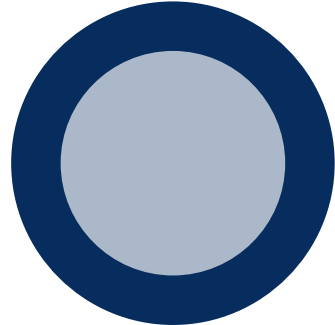
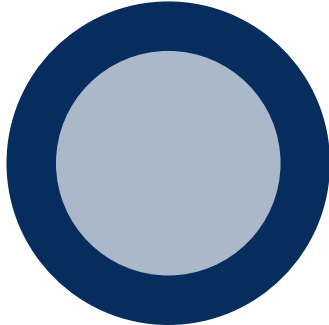
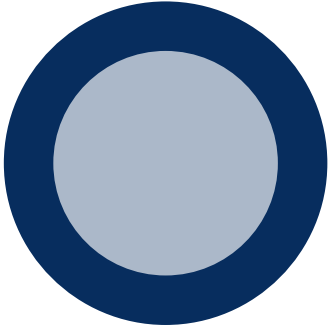
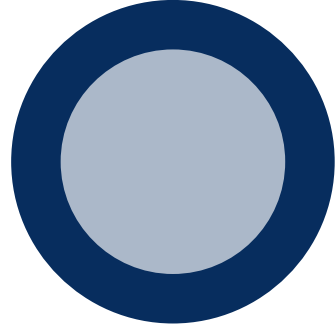
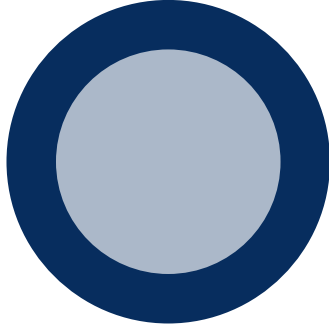
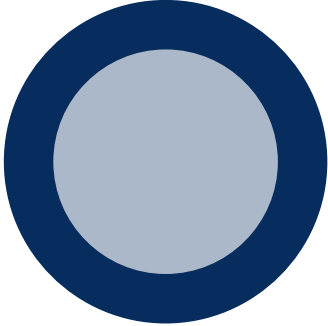



# Teaching Mind Growth My Life Gaming Controller

